A Basic “Fetch & Carry” Architecture for the youBot

Frederik Hegger, Jan Paulus,
Nico Hochgeschwender, Azamat Shakhimardanov

8. May 2012



Architecture Problems

- Think critically about the following diagrams, e.g. about
 - ... granularity
 - ... modularity
 - ... networkload
 - ...
- How did/would you design the architecture of our robotic system (youbot)?



Computational Architecture

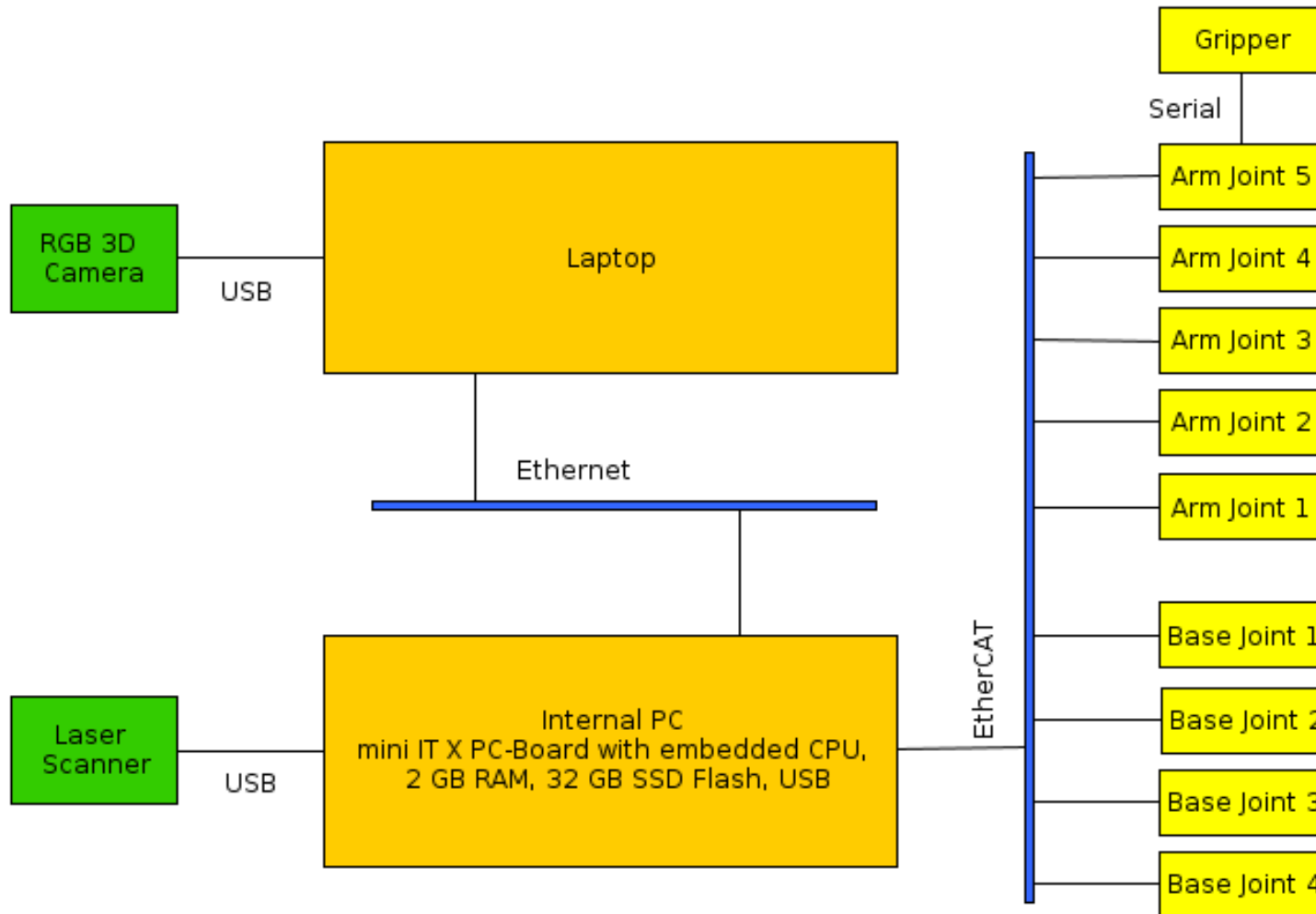



Functional Architecture

Coarse-grained

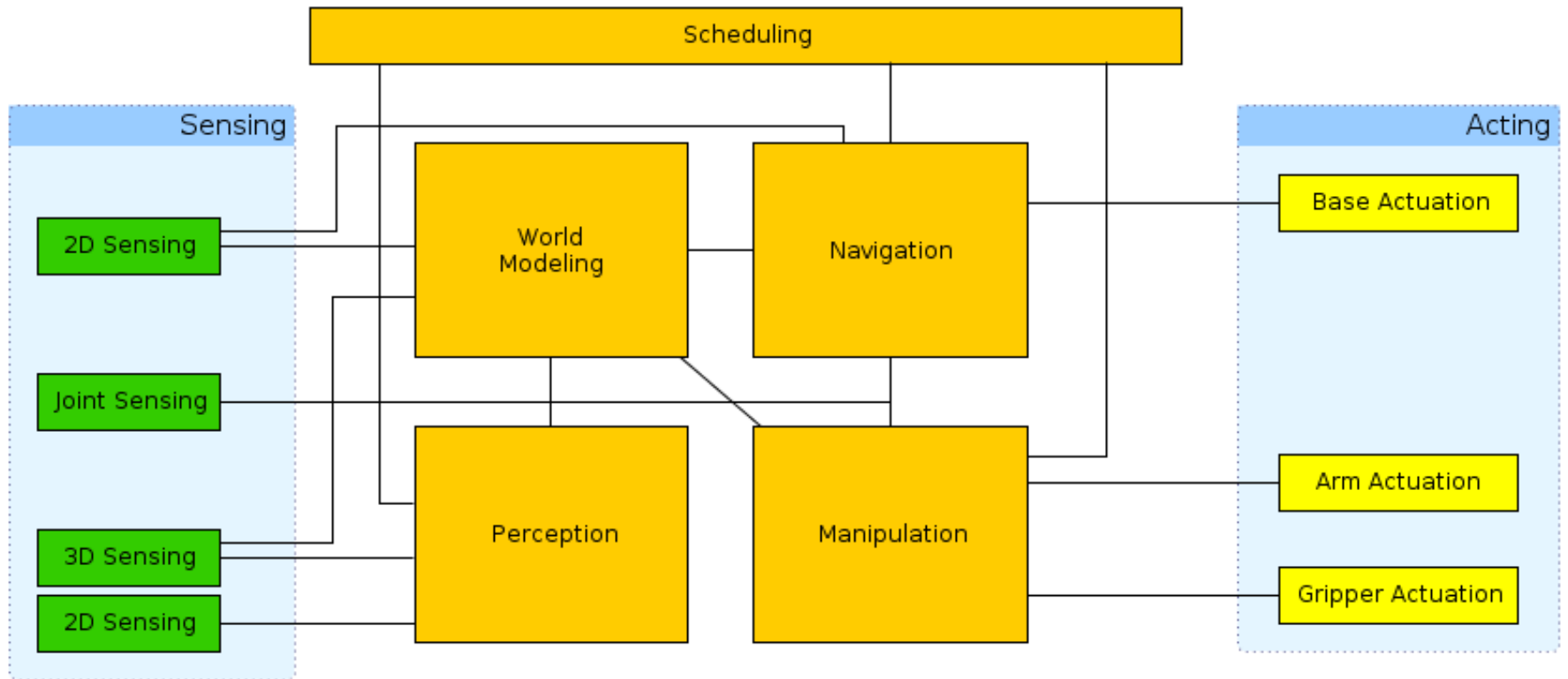

Functional Architecture

Fine-grained

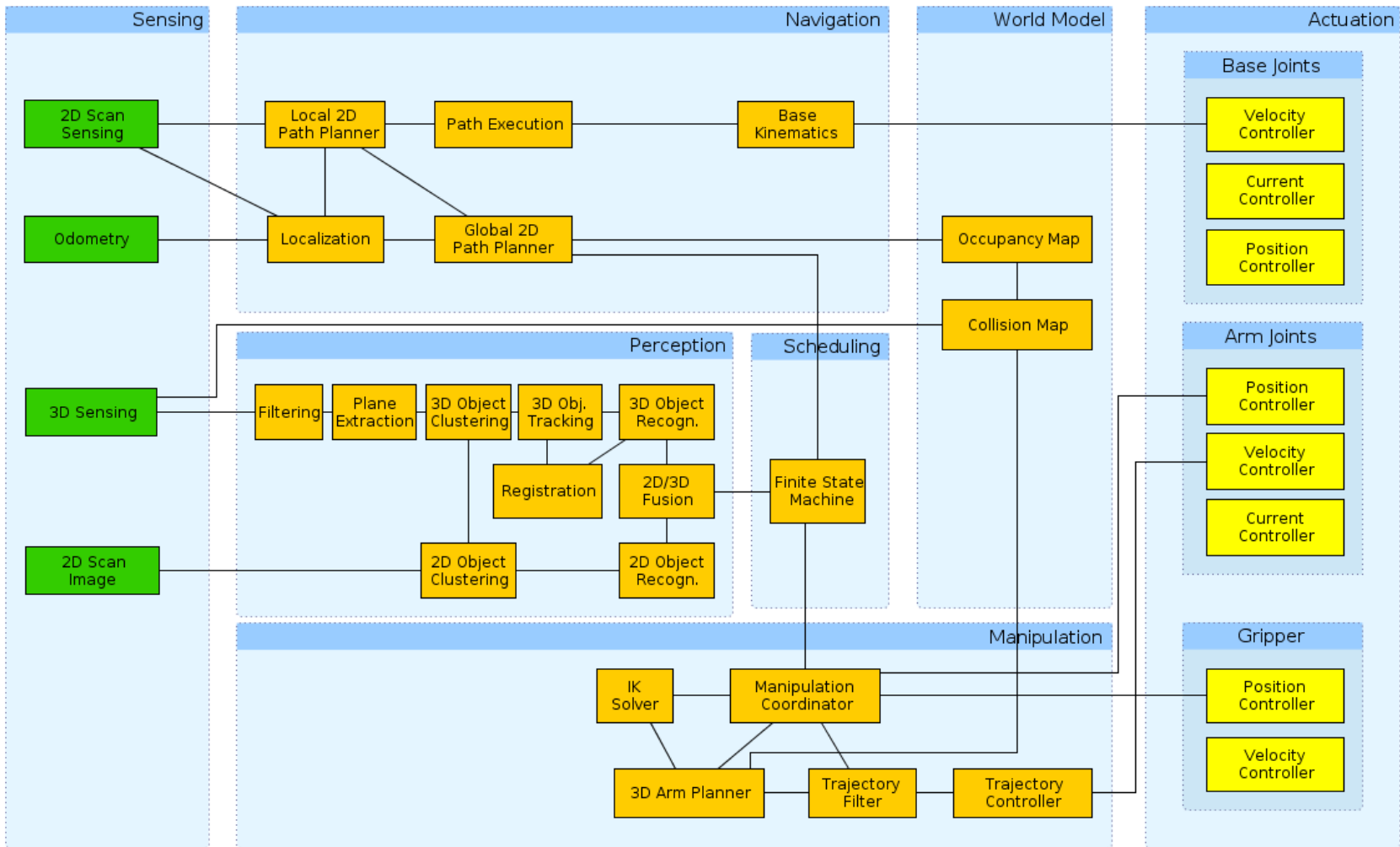



Functional Architecture

Integrated Features

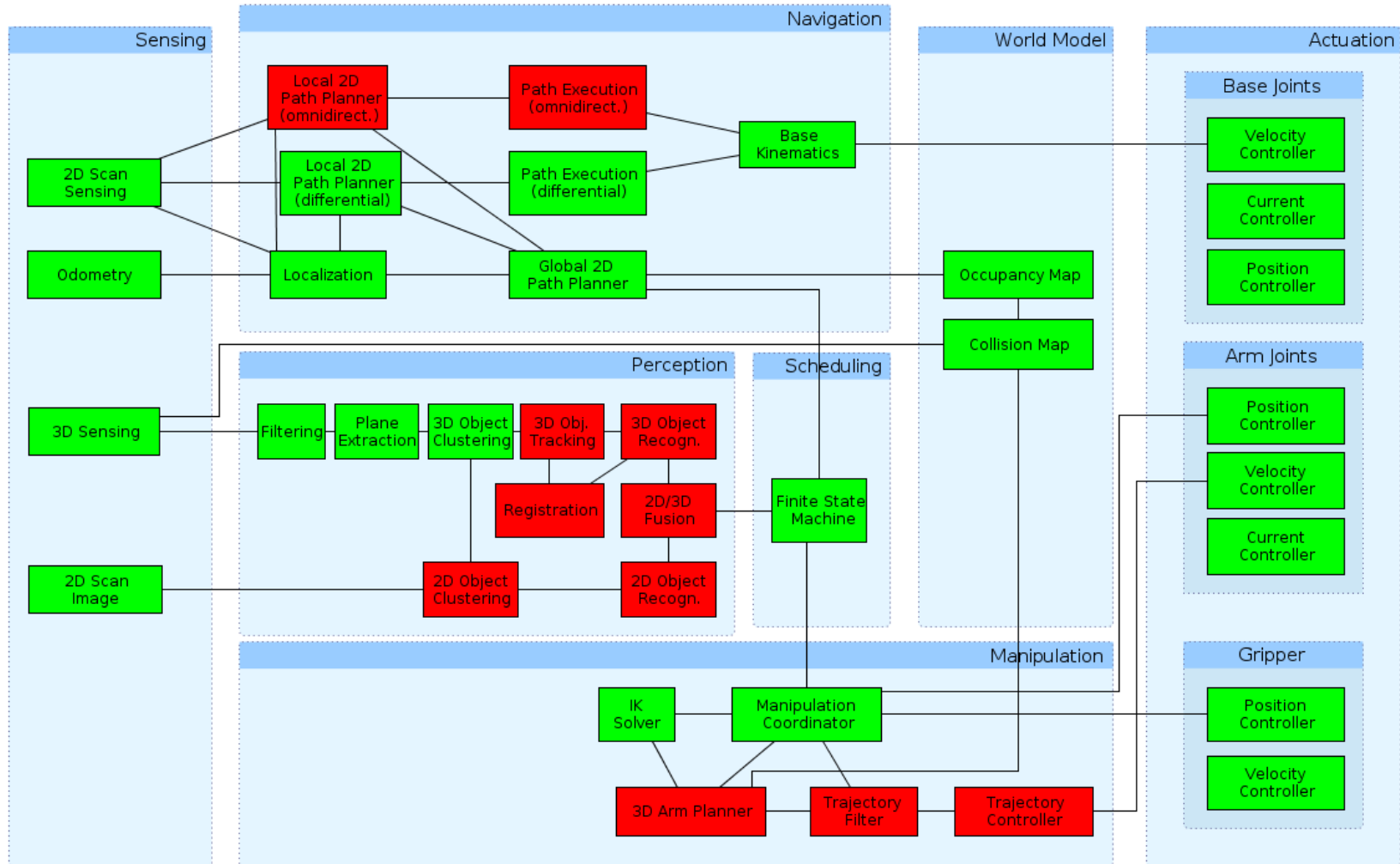



Deployment/Runtime Architecture

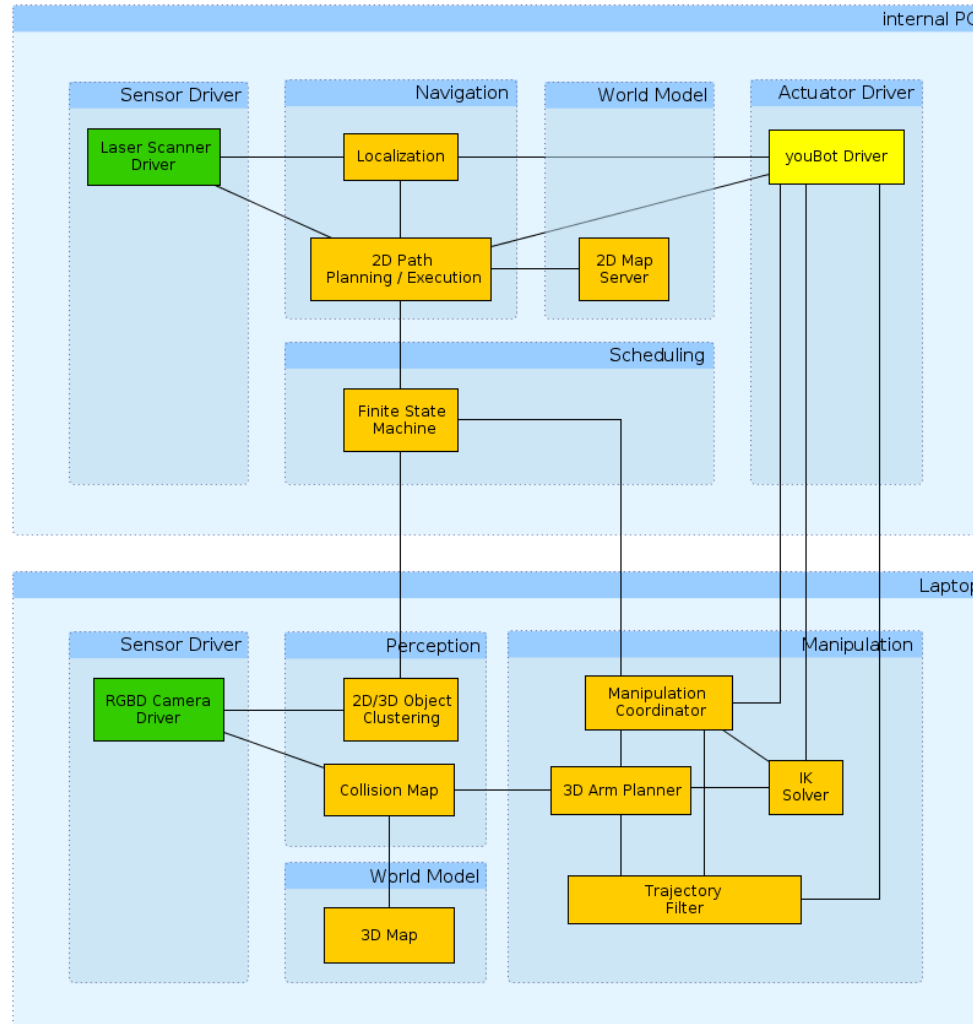



Discussion

Discussion